

Material & Finish :

Housing : Nylon 6T . UL 94v-0

Actuator : PPA . UL94V-0

Contact : Phosphor Bronze . Plating : Tin / Lead (Gold Plated is Available)

Solder Tab: Brass . Plating : Tin / Lead

Electrical Characteristics:

Operating Voltage : 100V Max

Current Rating : 0.5 Amp Max

Contact Resistance : 30m Min

Insulation Resistance : 500m Min

Dielectric Withstanding Voltage : 500V AC RMS

Environmental Characteristics:

Operating Temperature: - 40°C ~ +85°C

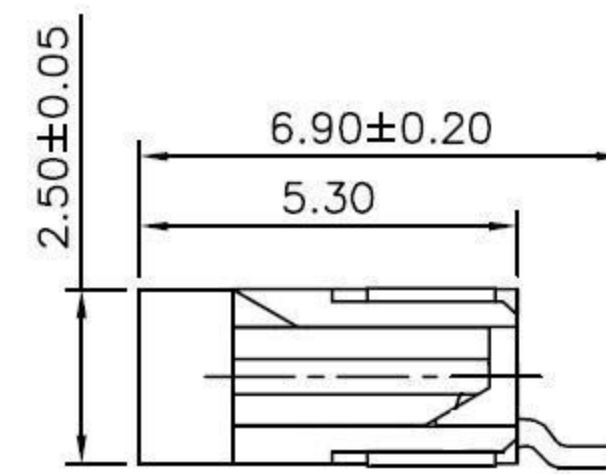
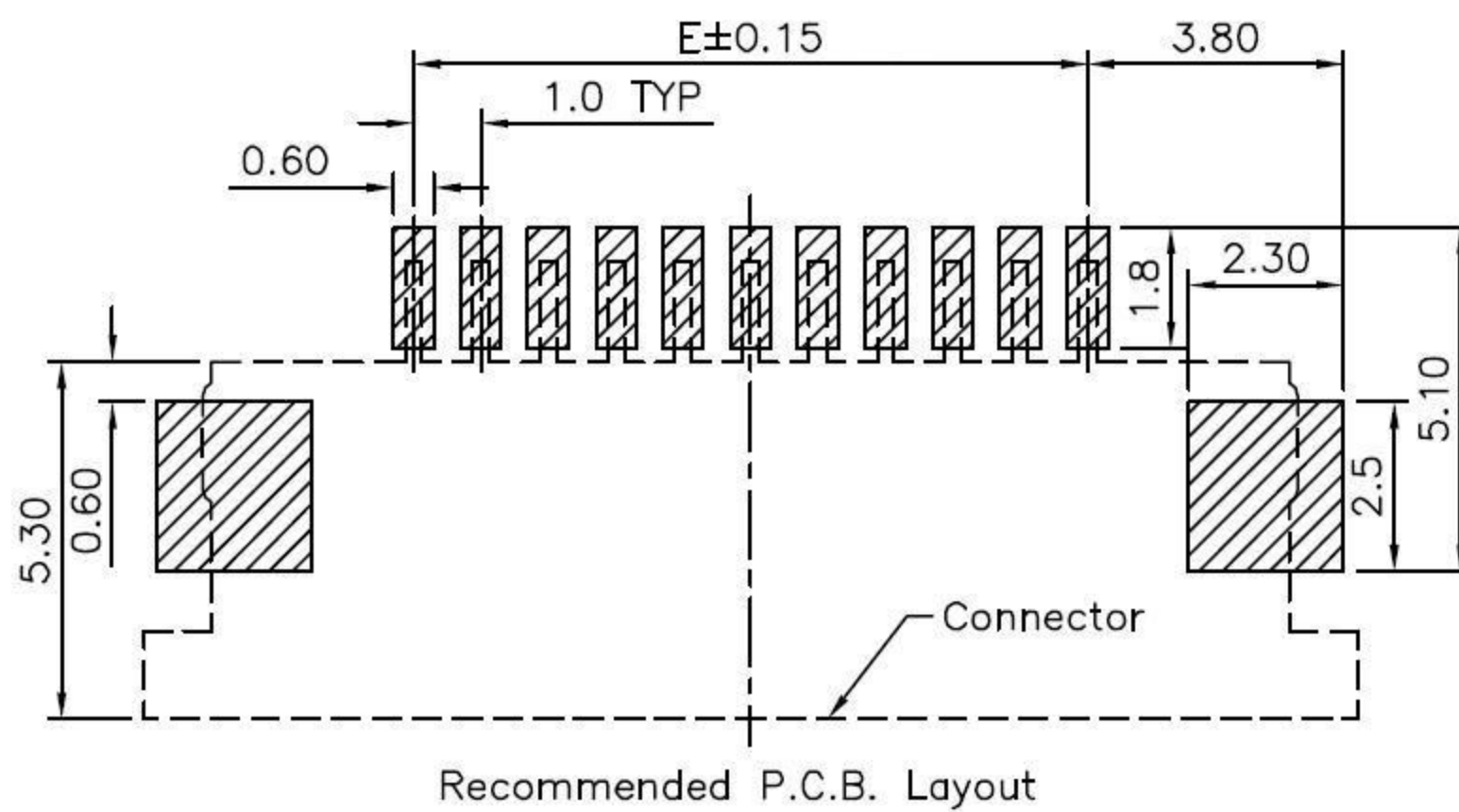
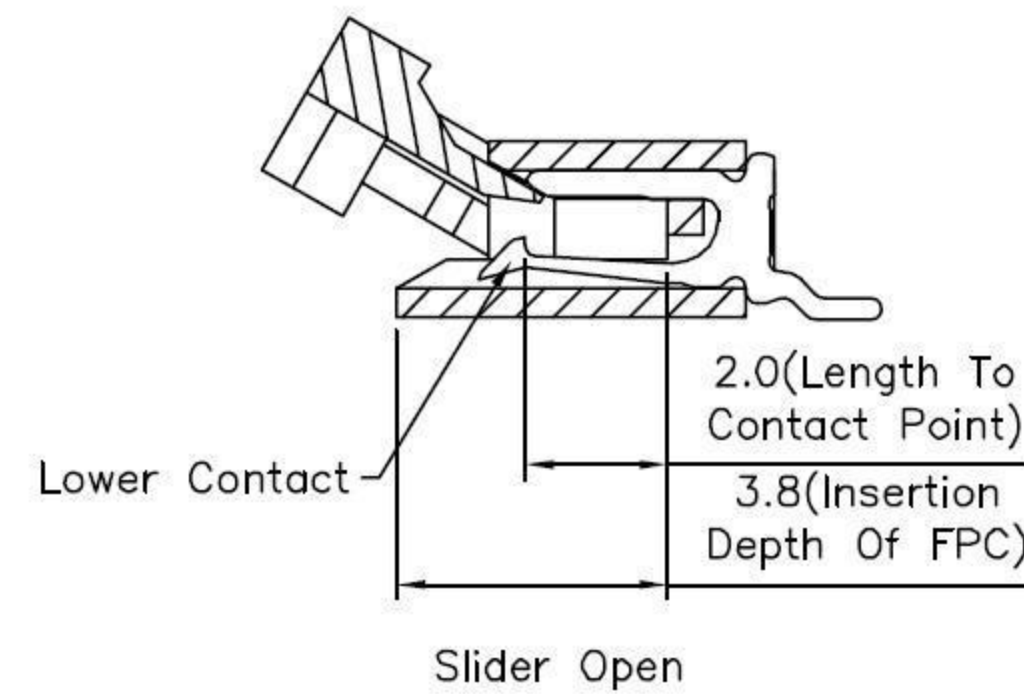
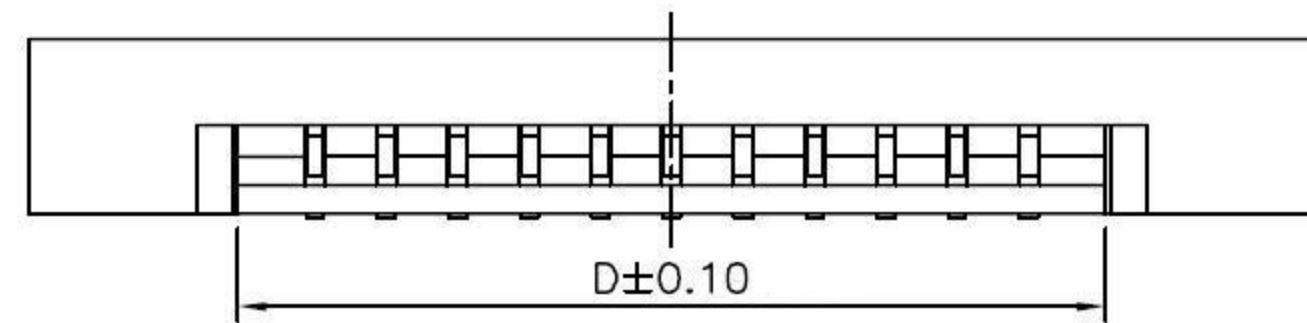

Pin	A±0.25	B±0.15	C±0.20	D±0.10	E±0.15
3	9.00	2.00	10.00	4.05	2.00
4	10.00	3.00	11.00	5.05	3.00
5	11.00	4.00	12.00	6.05	4.00
6	12.00	5.00	13.00	7.05	5.00
7	13.00	6.00	14.00	8.05	6.00
8	14.00	7.00	15.00	9.05	7.00
9	15.00	8.00	16.00	10.05	8.00
10	16.00	9.00	17.00	11.05	9.00
11	17.00	10.00	18.00	12.05	10.00
12	18.00	11.00	19.00	13.05	11.00
13	19.00	12.00	20.00	14.05	12.00
14	20.00	13.00	21.00	15.05	13.00
15	21.00	14.00	22.00	16.05	14.00
16	22.00	15.00	23.00	17.05	15.00
17	23.00	16.00	24.00	18.05	16.00
18	24.00	17.00	25.00	19.05	17.00
19	25.00	18.00	26.00	20.25	18.00
20	26.00	19.00	27.00	21.05	19.00
21	27.00	20.00	28.00	22.05	20.00
22	28.00	21.00	29.00	23.05	21.00
23	29.00	22.00	30.00	24.05	22.00
24	30.00	23.00	31.00	25.05	23.00
25	31.00	24.00	32.00	26.05	24.00
26	32.00	25.00	33.00	27.05	25.00
27	33.00	26.00	34.00	28.05	26.00
28	34.00	27.00	35.00	29.05	27.00
29	35.00	28.00	36.00	30.05	28.00
30	36.00	29.00	37.00	31.05	29.00
31	37.00	30.00	38.00	32.05	30.00
32	38.00	31.00	39.00	33.05	31.00
33	39.00	32.00	40.00	34.05	32.00
34	40.00	33.00	41.00	35.05	33.00



DIMENSION	mm	DATE	REVISION	APPROVAL BY
DRAW BY	Alex			
APPROVAL BY	Rikki			
DATE	03-12-08			

HOW TO ORDER

FPC10- XX M02

No. of Contacts Packing Type / = Tube
03 - 34 Pin R = Reel

DESCRIPTION: Pitch 1.0mm 90°Angle / SMT Flip-Lock ZIF Type /LowerContact